

BUILD FULLY AUTOMATIC AUTO THEFT ALARM

POPULAR ELECTRONICS

APRIL
1970

50
CENTS



NEW TOUCH ON/OFF CONTROL CIRCUIT

BETTER BASS RESPONSE WITH "FRISKY" SPEAKERS

SIMPLIFIED AM RECEIVER ALIGNMENT TOOL

GETTING TO KNOW THE UNIJUNCTION

PRODUCT GALLERY REPORTS:

- RCA IC Kits ● New De-soldering Tool
- Heathkit AR-29 ● Eico Curve Tracer
- Phase Corp. Pre-amp

BUILD DIGITAL LOGIC DEMONSTRATOR / MICROLAB



POPULAR ELECTRONICS

VOLUME 32 NUMBER 4

APRIL 1970

WORLD'S
LARGEST-SELLING
ELECTRONICS
MAGAZINE

FEATURE ARTICLES

- | | | |
|---|-----------|----------------------|
| BUILD THE DIGITAL LOGIC MICROLAB
<i>A super breadboard for learning logic</i> | 27 | Don Lancaster |
| ELECTRONICS GEOGRAPHY QUIZ | 42 | Thomas Haskett |
| THE FRISKY FOUR SPEAKER SYSTEM
<i>Small speakers give top response</i> | 43 | David B. Weems |
| MICRO'LIGN GENERATOR
<i>Low-cost signal source</i> | 48 | Michael S. Robbins |
| TC SWITCH—FOR REMOTE CONTROL
<i>One touch does it</i> | 52 | Jack Bechtold |
| BUILD THE 100-kHz STANDARD
<i>Stable source of square waves</i> | 56 | Don Lancaster |
| AUTOMATIC VEHICLE BURGLAR ALARM
<i>Works when others don't</i> | 59 | George Meyerle |
| GETTING TO KNOW THE UJT
<i>Explains the unijunction transistor</i> | 69 | Frank H. Tooker |
| TIPS & TECHNIQUES | 74 | |
| DEHUMMING SMALL RECEIVERS | 75 | Ronald L. Ives |
| THE PRODUCT GALLERY | 77 | |
| <i>Eico Semiconductor Curve Tracer</i> | | |
| <i>Heathkit AR-29 Stereo Receiver</i> | | |
| <i>Phase Corp. Four-Trace Pre-Amp</i> | | |
| <i>RCA Integrated Circuit Kits</i> | | |
| <i>Continental De-Soldering Tool</i> | | |
| OPPORTUNITY MIRROR | 83 | David L. Heiserman |
| SOLID STATE | 86 | Lou Garner |
| TWO-WAY REACTIONS | 93 | G. H. Reese, KC6990 |
| ENGLISH LANGUAGE NEWS BROADCASTS TO N.A. | 94 | Roger Legge |
| AMATEUR RADIO | 95 | Herb S. Brier, W9EGQ |
| SHORT-WAVE LISTENING | 97 | Hank Bennett, W2PNA |

DEPARTMENTS

- | | |
|---------------------------------|----------------|
| LETTERS FROM OUR READERS | 8 |
| ELECTRONICS LIBRARY | 14 |
| READER SERVICE PAGES | 15, 115 |
| NEW LITERATURE | 16 |
| NEW PRODUCTS | 22 |
| OPERATION ASSIST | 104 |
| OUT OF TUNE | 105 |
- Two-Tone "Waverly" Alarm (February 1970)*

POPULAR ELECTRONICS is indexed
in the Readers' Guide
to Periodical Literature

Copyright © 1970 by ZIFF-DAVIS PUBLISHING COMPANY. All rights reserved.

This month's cover photo by
Conrad Studios

POPULAR ELECTRONICS, April 1970, Volume 32, Number 4, Published monthly at One Park Ave., New York, N.Y. 10016. One year subscription rate for U.S., U.S. Possessions and Canada, \$6.00; all other countries, \$7.00. Second class postage paid at New York, N.Y. and at additional mailing offices. Authorized as second class mail by the Post Office Department, Ottawa, Canada and for payment of postage in cash. Subscription service and Forms 3579: P.O. Box 1096, Flushing, N.Y. 11352. Editorial offices for manuscript contributions, reader inquiries, etc.: One Park Ave., New York, N.Y. 10016.

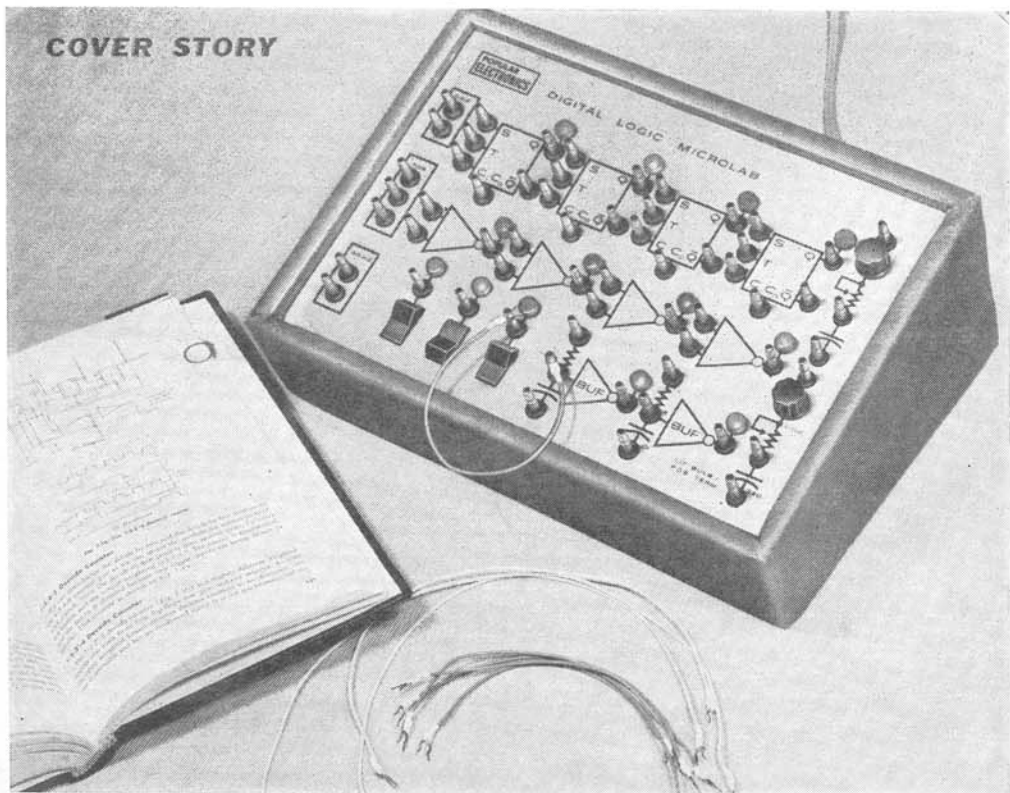

BUILD THE Digital Logic Microlab

LEARN HOW DIGITAL CIRCUITS WORK—THE EASY WAY

BY DON LANCASTER

DIGITAL LOGIC is involved in a great number of experimental projects and in instruments used daily in the laboratory. Despite the fact that digital logic circuits are so commonplace, the principles involved are not always too well understood. To remedy this situation, you will want to build a "Digital Logic Microlab"—an advanced breadboarding device that lets you quickly and painlessly verify all the basics of digital logic. It will serve as a teaching aid for yourself and others; and it is an excellent science fair project.

The Microlab can also serve as a universal digital test and debugging instrument, providing such functions as bounceless contacts, state checkers, mon-

itors, precision one-shot time gates, synchronizers, and cycling oscillators. Although the Microlab is designed to use resistor-transistor logic (RTL), to make it compatible with the majority of projects described in *POPULAR ELECTRONICS*, it can easily be adapted to work with diode-transistor logic (DTL), transistor-transistor logic (TTL) or Utilogic® (Signetics Corp.) systems.

The Microlab includes four JK flip-flops, four two-input gates, two buffers, and three bounceless mechanical switches and can be used in over 100 basic logic experiments (see page 35). Each logic block has its own pilot-light readout to indicate the state of its output and the power supply and ground connections for

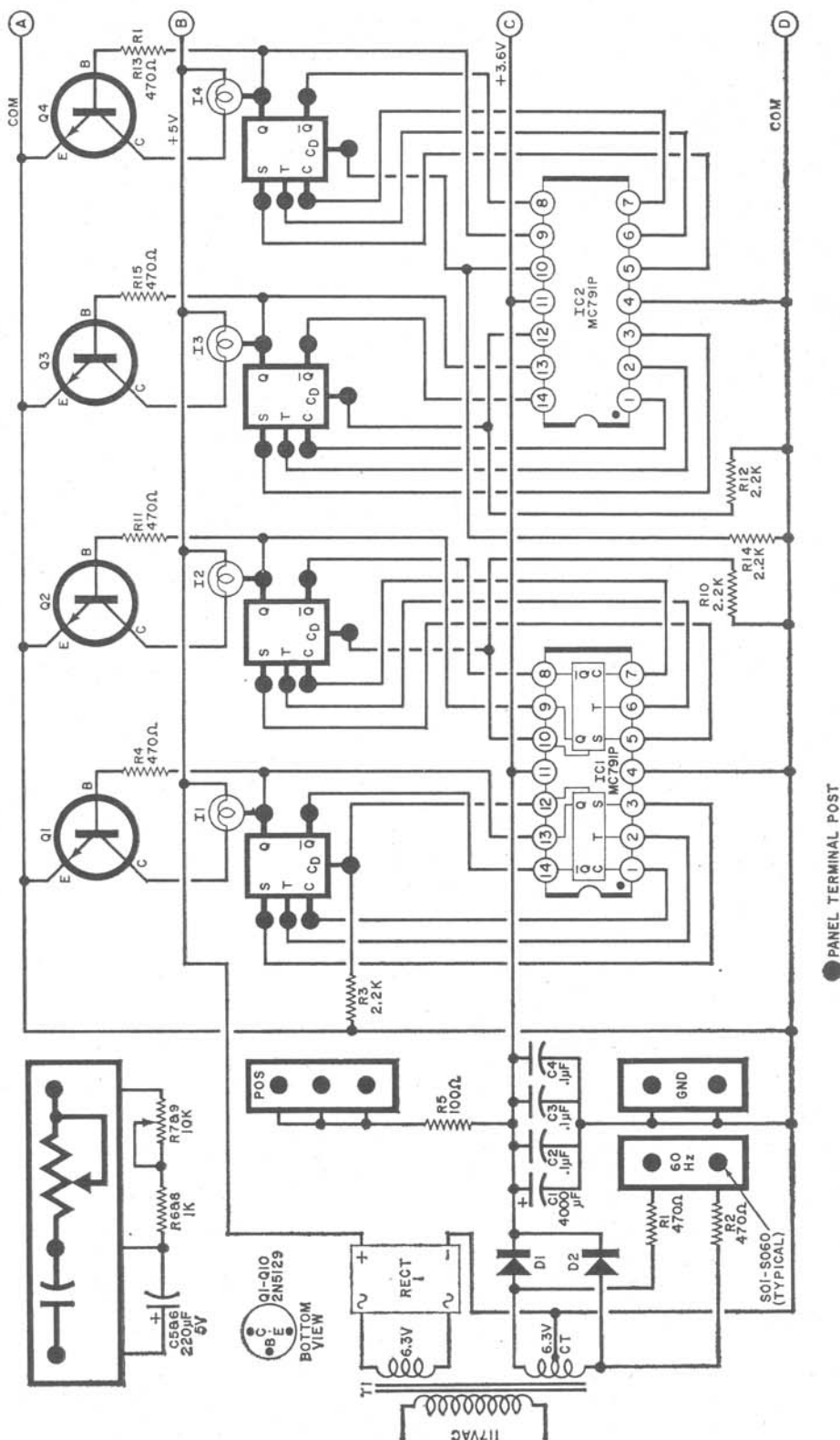
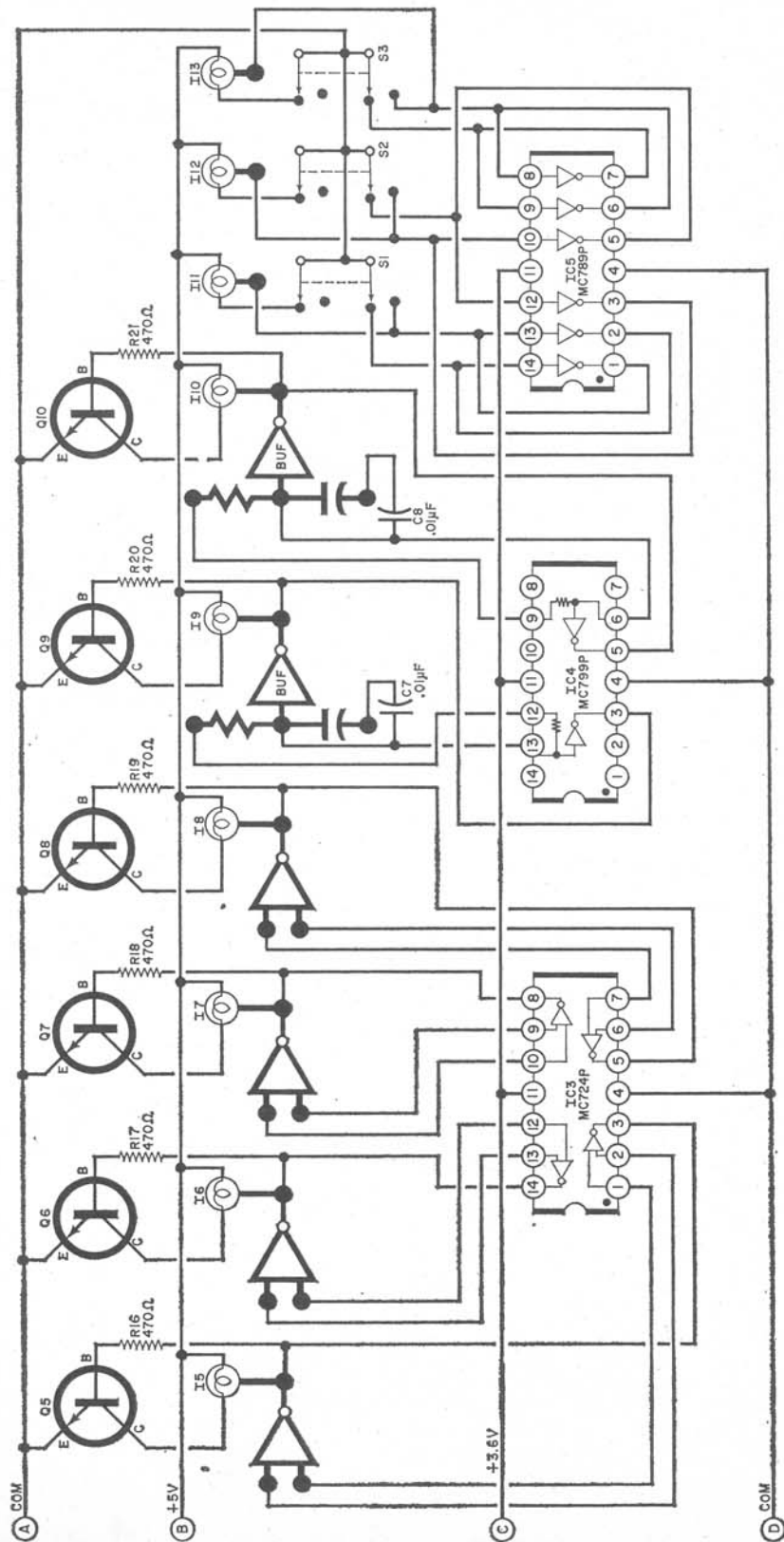

Fig. 1. Complete schematic diagram of Microlab is shown here in two parts; points A, B, C, and D in each half connect to their respective letters, Logic, schematic, and post designations on the front panel—not circuit board—are shown in bold lines. These lines refer to functions inside the IC's and outboard connections.



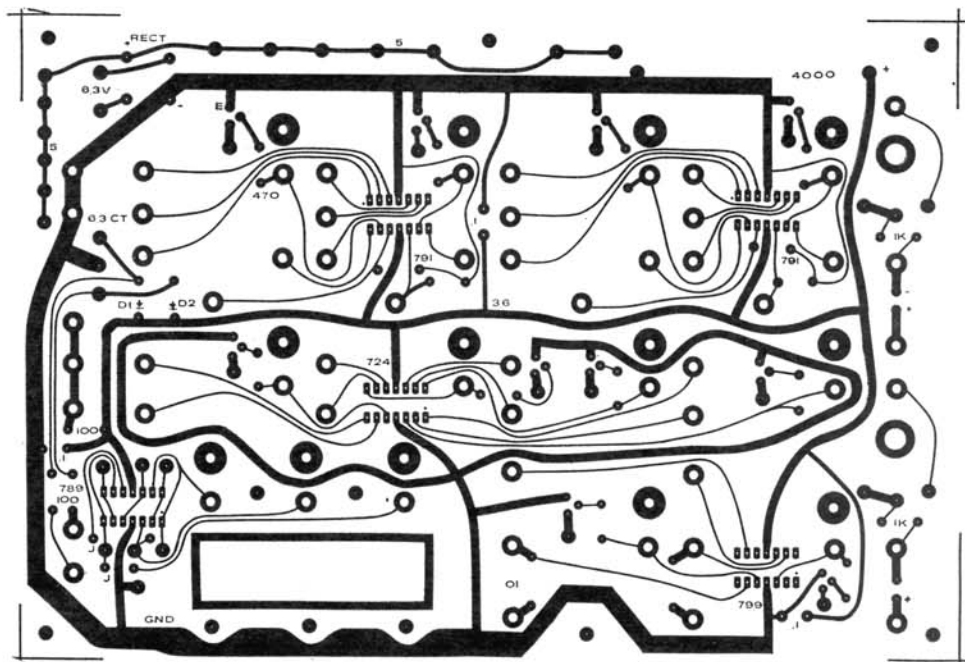

Fig. 2. Foil pattern etching guide is shown here half-size. The best method of obtaining a full-size guide is to use photographic blow-up. However, board is available from the source specified in Parts List if you prefer not to make your own.

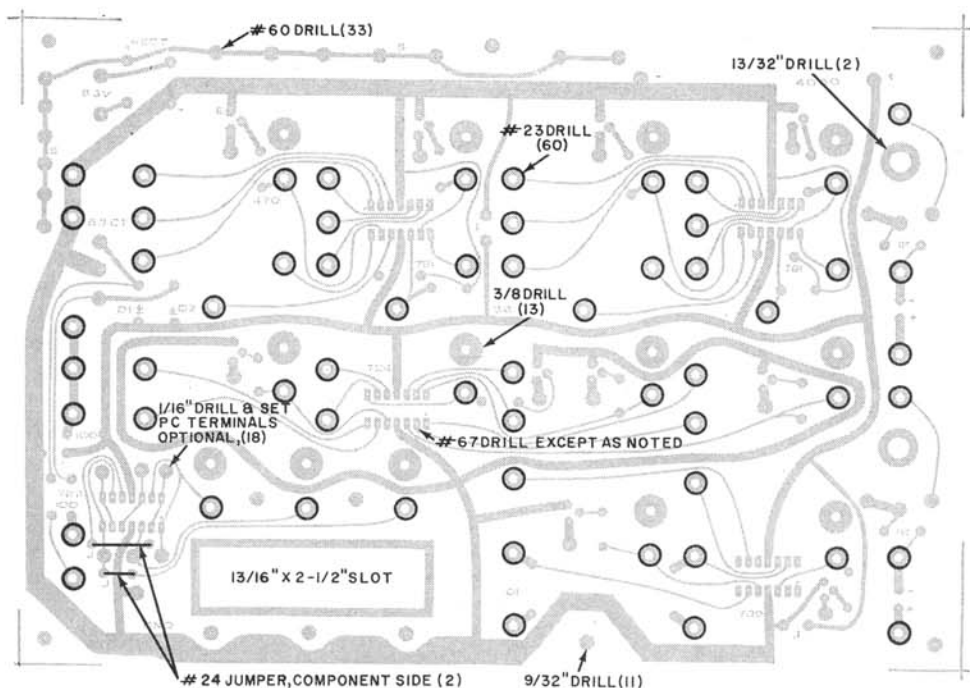

Fig. 3. Circles around solder pads indicate locations of terminal posts. Slot at bottom is to provide clearance for switches. Note jumpers at lower left of illustration.

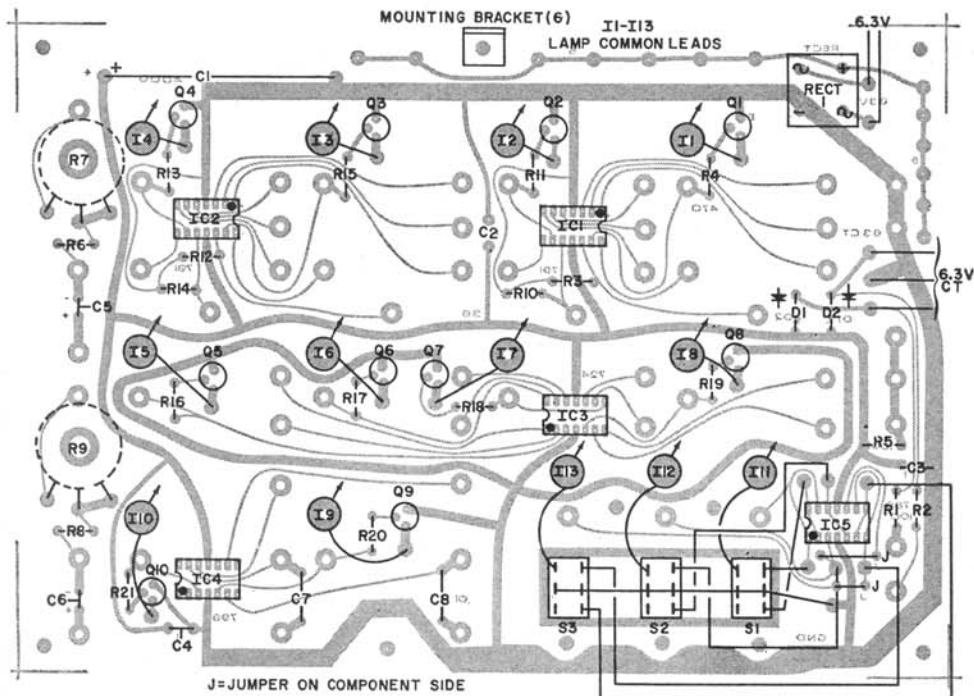

Fig. 4. Be extremely careful when mounting components on circuit board to observe proper lead orientations. Terminal ends of S1-S3 pass through slot in board (lower right) and terminals connect to appropriate points in circuit via wire.

each block are permanently installed and properly bypassed. In using the Micro-lab, all you do is make the logic connections using simple "zip" leads that require no soldering and are easy to attach and remove.

Three types of input signals are available on the front panel: a constant-value positive voltage, the 60-Hz power line that can be properly conditioned for driving the logic blocks, and three conditioning actuators that may be used as either

PARTS LIST

C1—4000- μ F, 6-volt electrolytic capacitor
 C2-C4—0.1- μ F, 10-volt disc ceramic capacitor
 C5, C6—220- μ F, 6-volt electrolytic capacitor
 C7, C8—0.01- μ F, 50-volt Mylar capacitor
 D1, D2—1-ampere, 25-volt silicon power diode (1N4001 or similar)
 I1-I13—5-volt, 50-mA pilot lamp and color-coded lens (3 green, 4 blue, 2 red, 4 orange)
 IC1, IC2—Dual JK flip-flop (Motorola MC791P)
 IC3—Quad two-input gate (Motorola MC724P)
 IC4—Dual buffer (Motorola MC799P)
 IC5—Hex inverter (Motorola MC789P)
 Q1-Q10—Transistor (National or Fairchild 2N-5129, available from New Jersey Semiconductor, 20 Commerce St., Springfield, NJ 07081)
 R1, R2, R4, R11, R13, R15-R21—470-ohm, $\frac{1}{4}$ -watt resistor
 R3, R10, R12, R14—2200-ohm, $\frac{1}{4}$ -watt resistor
 R5—100-ohm, $\frac{1}{4}$ -watt resistor
 R6, R8—1000-ohm, $\frac{1}{4}$ -watt resistor
 R7, R9—10,000-ohm, linear potentiometer
 RECT1—1-ampere, 25-volt diode bridge assembly

S1-S3—D.p.d.t. rocker switch

T1—Filament transformer, secondaries: 6.3 volts at 0.5 amperes, 6.3 volts center-tapped at 0.5 amperes; or two separate transformers.

Misc.—Match-drilled dialplate; 5-ferrule terminal posts (Southwest Technical #TP-7563-3GD or similar, 60 required); vinyl grommets (60); vinyl-clad wood case; heat-shrinkable tubing (2 ft); red lead wire (15 ft); yellow lead wire (9 ft); plated hair pin cotters (Southwest Technical PHPC-43, 80 required); $\frac{1}{2}$ -inch knobs (2); line cord; wire nuts (2); mounting brackets with hardware (6); switch bracket and hardware; epoxy cement; #24 solid wire; sleeving; $\frac{1}{4}$ " nylon nuts or other insulated spacers (7); PC terminals (18, optional); solder, etc.

Note—The following are available from Southwest Technical Products, Box 16297, San Antonio, TX 78216; etched and drilled printed circuit board #997, \$10.50; complete kit of all parts including front panel and vinyl-clad case #997-K, \$26.75; 240-page experimenter laboratory manual #B-1, \$5.25; all prices postpaid. All individual parts are also available.

Fig. 5. Photo shows how to layout and label the front panel.

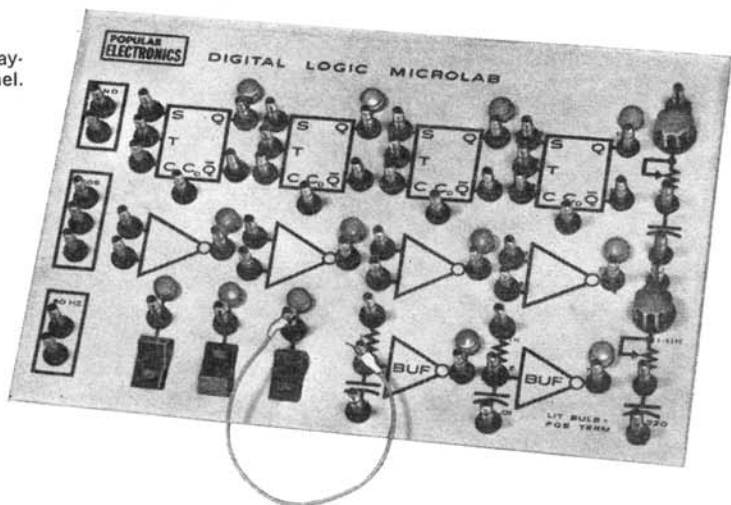

pushbuttons or slide switches. The latter are bounceless and can drive all logic blocks. If desired, certain blocks may be interconnected to form oscillators for driving or test purposes.

Another important feature of the Microlab is that, if you are going to use it as a teaching aide, the entire instrument is "student proof" in that no possible combination of panel connections, however wrong, can damage the circuits.

You can build the Microlab for \$20 to \$30 using the printed circuit boards and complete kits mentioned in the Parts List for Fig. 1. A 240-page experimenter's manual is also available.

What Do the Logic Blocks Do? In general logic blocks perform "yes-no" decisions based upon the presence or absence of "yeses" and "nos" at their inputs. Each block follows a predetermined set of rules and always does the same thing in response to a particular set of input conditions.

There are four types of logic blocks in the Microlab: *two-input gates*, *buffers*, *counting flip-flops* (called JK flip-flops by the computer people), and *inverters*, the latter being inside the unit. The principal components in the blocks are RTL integrated circuits. The outputs of each block are either grounded or at some positive potential (between 1.5 and 3.6 volts), depending on the presence or absence of similar positive or grounded conditions on the inputs.

Two-Input Gate. The logic rule for the

two-input gate states that, if both inputs are grounded, the output is positive; and if either one or both of the inputs is made positive, the output is grounded. If you call ground a "yes" and positive a "no", the two-input gate is a NAND gate. On the other hand, if you call positive a "yes" and ground a "no", you have a NOR gate. The choice is up to you. By combining these gates, all the remaining logic functions can be generated. Two-input gates may also be used to form flip-flops and perform decoding and decision logic.

Buffer. A buffer is an inverting high-power one-input gate and is used where lots of output drive is needed. Its logic rule is simple: if the input is positive, the output is grounded; and vice versa.

A capacitor and resistor are also connected to the buffer's input. If you connect the buffer normally, you simply leave both these components floating. If you connect the resistor to positive and the input to the capacitor, a sudden positive-to-ground transition on the input will produce a brief positive output pulse lasting only several microseconds. This type of pulse is used to reset counting chains or to recognize the beginning, but not the duration, of some event.

Although such an arrangement is seldom used, the resistor can be grounded and a sudden ground-to-positive transition applied to the capacitor. In this case the buffer's output is normally positive and goes to ground briefly for a few microseconds.

Buffers are used as amplifiers to increase drive capability and as reset pulse generators for counters; or, when used in pairs, they may be cross-coupled to form an oscillator or latch.

Counting Flip-Flop. This is the most complex of the logic blocks in the Microlab. Each flip-flop has two outputs, called Q and \bar{Q} , and four inputs, S , T , C , and C_D . The Q and \bar{Q} outputs are complementary. This simply means that, if one is positive, the other is grounded, and vice versa. The inputs are used to make the flip-flop's outputs either change states or stay the way they are.

The C_D input is called a direct input. It is normally left grounded or unconnected. If it is made positive, the flip-flop will immediately go to the state where Q is grounded and \bar{Q} is positive. This is used to initially set the states on a number of flip-flops or to reset a flip-flop. After such a resetting, the C_D input must be returned to ground to allow the other inputs to function.

Inputs S , T , and C are normally used together and are called *clocked* inputs. No matter what happens to the S and C inputs, nothing happens to the outputs until the T input suddenly changes from positive to ground. The rules are as follows:

1. If both S and C are grounded, the output changes state when the T input suddenly goes from positive to ground.
2. If S is grounded and C is positive, and the T input suddenly goes from positive to ground, the outputs are ground at Q and positive at \bar{Q} .
3. If S is positive and C is grounded, and the T input suddenly goes from positive to ground, the outputs are positive at Q and ground at \bar{Q} .
4. If both S and C are positive, nothing happens when the T input goes from positive to ground.

The clocked nature of the JK inputs permits us to set up what the flip-flop is going to do before it actually does it. This is the key to the operation of counters, registers, sequencers, synchronizers, and many other circuits which use clocked flip-flops.

Inverter. The inverter—there are six inside the Microlab—is a low-power buffer. A positive input produces a ground at the output and vice versa. The six inverters are used to make the three con-

ditioning switches bounceless so that they properly drive the T inputs of the flip-flops. Conditioning is accomplished by cascading two inverters to form a set-reset latch whose output is a fast-rise square wave, independent of any contact bounce and noise.

Construction. The Microlab is built in three major parts: a large printed circuit board on which are mounted all of the parts except the power transformer, a front panel that displays the logic symbols and makes available the required connections, and a sloping-front vinyl-clad cabinet.

The schematic is shown in Fig. 1. Since the PC board is so large, a half-

HOW IT WORKS

The Microlab contains five IC's, a dual power supply, and some discrete components. One power supply provides +3.6 volts of filtered, bypassed d.c. for the logic circuits; a current-limited positive voltage reference for the front panel; and a split-phase, current-limited 60-Hz reference. The other supply provides 5 volts of full-wave rectified but unfiltered d.c. to drive the state-indicating pilot lights. Either a single tapped transformer or two filament transformers may be used.

The logic circuits in each IC are brought out to the front panel. For instance, $IC1$ and $IC2$ are dual JK (counting) flip-flops. Each of the four independent flip-flops is brought out to its own symbolic terminal grouping on the front panel. Resistors are added to the C_D inputs so that they may be safely left unconnected.

Each logic block has its state indicated by a pilot light driven by a npu silicon transistor having a base-current limiting resistor. When the output terminal is positive, the lamp lights.

The four two-input gates in $IC3$ are also brought out to symbolic terminals on the front panel; as are the two buffers in $IC4$. The 1000-ohm resistors shown in the inputs are internal to the IC, while two capacitors are added as shown. These are useful for pulse and reset generation and for cross-coupling of two buffers to build a high-frequency oscillator.

Hex inverter $IC5$ is used to form three bounceless actuators in conjunction with $S1$, $S2$, and $S3$. This permits direct driving of the T inputs of the flip-flops without erratic triggering. An extra contact on each switch directly controls a pilot light when the post output is positive, saving three driver transistors and three resistors.

Two networks on the right side of the front panel complete the circuit. Each of these consists of a potentiometer, a fixed resistor, and an electrolytic capacitor. They are used with the two-input gates to form either a monostable multivibrator (one network) or an astable low-frequency oscillator (two networks) adjustable over a 10:1 range from several cycles per second to a cycle every second or so. The values have been selected for optimum visual demonstration of logic and count sequences.

size foil pattern is shown in Fig. 2. If you make your own board, match drill it to the front panel so that all 60 terminal posts are correctly registered—within the play of the rubber grommets that insulate the board from the panel if the latter is metal.

Using Fig. 3. as a guide, press fit each terminal post into place on the foil side of the board, making sure that each post is vertical to the board. Press the posts down so that the first ferrule is in contact with the board. Solder them in place. After soldering, turn the board over and either stake or cement (with epoxy) each post in place. Mount the other components in accordance with Fig. 4, using a low-power iron and fine solder. Note that not all of the IC's are mounted the same way. Follow the notch and dot code on each IC body to position it correctly.

The three switches are mounted $\frac{1}{4}$ " below the component side of the board on a suitable standoff bracket. L-brackets are then attached to the component side of the board as shown. These brackets will be used to support the PC board assembly on the case.

Prepare the front panel as shown in Fig. 5. Be sure that the holes in the panel align with the appropriate components—terminal posts, switches, and potentiometers. Drill holes for and mount the 13 pilot light lenses. In the prototype, orange lenses were used for the four IC displays, blue for the two-input gates, red for the two buffers, and green for the three switch indicators. These lenses press fit into place and can be glued for extra security. The holes for the terminal posts should have enough leeway to permit the installation of $\frac{1}{4}$ " grommets. (As noted in the Parts List, a front panel can be purchased.)

Before attaching the PC board to the front panel, wire up the pilot lights. Check that you have enough lead length on each lamp so that it can be fitted into place before mating the board with the front panel. Place a couple of $\frac{1}{4}$ " insulating spacers (nylon nuts are fine) over a few of the terminal posts to keep the board from contacting the metal front panel.

Ease the front panel and PC board together slowly, starting by aligning each grommet on its post and applying only enough pressure to register against the

grommets. As you ease the two components together, apply pressure to each grommet every time around. After several "rounds" of pressure, the board and front panel can be seated together perfectly. The operation is simple; but, if you hurry, a grommet may pop out. If you ever want to separate the board from the panel, simply reverse the procedure (see Fig. 6).

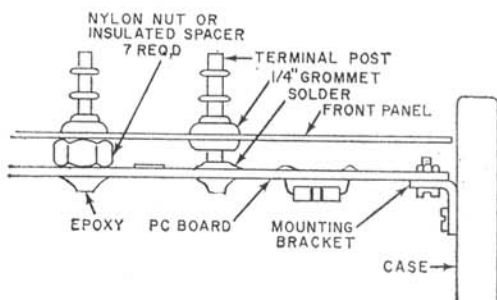

Fig. 6. Nylon spacers prevent circuit board from shorting against metal front panel. Rubber grommets keep terminal posts from contacting panel.

The supporting case is made from wood or particle board and may be covered with vinyl if desired. The PC board and front panel assembly is fitted into the case and secured with wood screws through the L-brackets. The power transformer is then attached to the cabinet interior as desired and wired to the board. Though they are not really necessary, an optional on-off switch and fuse may be added at this time.

Making the Zip Leads. The wires used to make connections on the front panel are called "zip" leads. Each is made of a length of insulated wire (size is not critical but #22 is good), two $\frac{3}{8}$ "-long pieces of heat-shrinkable tubing, and two $\frac{3}{32}$ "-diameter plated hair pin cotters. Unplated hair pin cotters, such as GC Electronics #7378, may be used if they are cleaned carefully before soldering.

For general experimenting, about 40 leads (perhaps 30 red ones 6" long and 10 yellow ones 10" long) will be required. To make a zip lead, cut the wire to the proper length and strip $\frac{1}{4}$ " of insulation from each end. Slip a piece of heat-shrinkable tubing over each end and solder a hair pin cotter to each end. Then

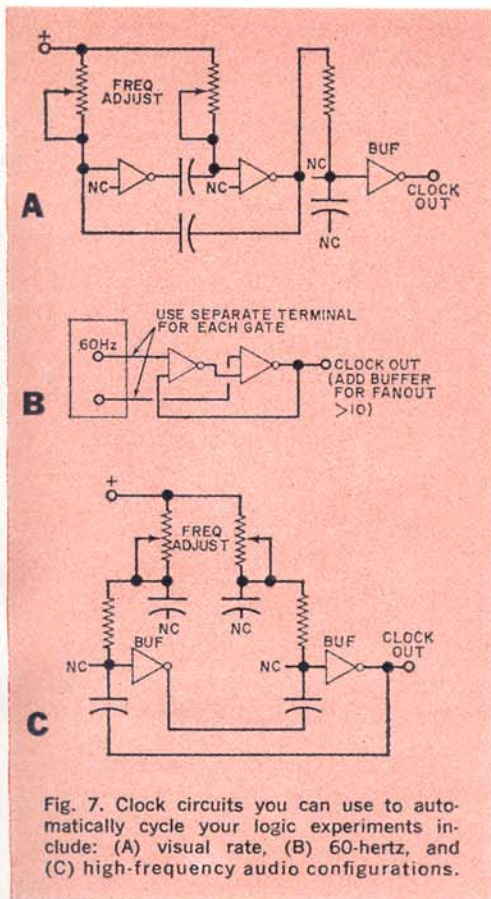
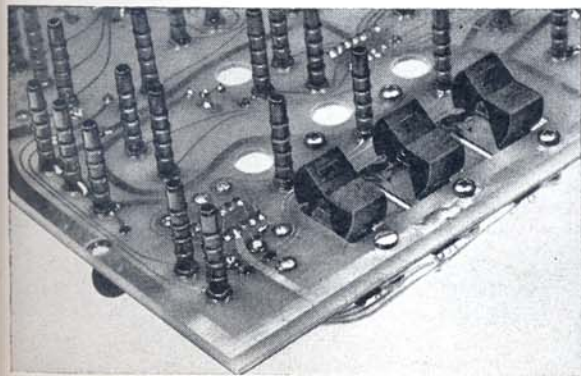

Fig. 7. Clock circuits you can use to automatically cycle your logic experiments include: (A) visual rate, (B) 60-hertz, and (C) high-frequency audio configurations.

slip the tubing over the joint and heat it to shrink it in place. You can do a very neat shrinking job by holding the tubing lightly against the ceramic portion of a screw-in-element soldering iron and rotating slowly.



OVER A HUNDRED CIRCUITS YOU CAN BUILD WITH THE MICROLAB

GATES AND BUFFERS:

Buffer amplifier, positive pulser, negative pulser, high- or low-frequency astable; logic demonstrators—2-input OR, NOR, AND, NAND, EXOR, EXNOR, positive or negative logic, 3-input OR, NOR, AND, NAND, positive or negative logic, 4-through-8-input OR, NOR, positive and AND/NAND negative logic; binary encoder and decoder; inverter demonstrator.

TYPES OF MULTIVIBRATORS:

RS flip-flop; set-reset latch; edge trigger latch; monostable multi-, high-, or low-frequency, buffered or load-isolated; half monostable; reset pulse generator; astables, including load isolated, sure start, symmetric, VCO, and negative recovery types; frequency doublers and quadruplers; risetime improvers; squaring circuits; linear amplifier modification.

COUNTERS, REGISTERS, AND SCALERS:

Binary up or down counters, modulo 2,4,8, and 16; synchronous binary 2,4, and 8; shift registers, 1,2,3, and 4 bit; shift register counter, modulo 3,7, and 15; walking ring counters, 2,4,6, and 8, including protected 6 and 8; odd length walking ring counters, 3,5, and 7; factored counters, 2,4,6,8,9,10,12,14, and 16; half-way addition counters, 3,5,6,7,9,10,11,12, 13,14,15; pseudo-random counter sequencers 7 and 15; even-odd reduction modulo 3, 5, and 9; bucket brigade counters, open ended or closed, modulo 1,2,3, and 4; decoded counters, 2,3,4, and 5.

OTHER CLOCKED FLIP-FLOP CIRCUITS:

Sequential pass-ons, 1,2,3, and 4; divide-by-two synchronizer; gated divider; straight synchronizer; one-and-only-one; sequencer; demonstrators, JK, T, D, and RS; type D registers, rings, binary dividers, and sequential pass-ons; disallowed state 2/6 and 2/8 demonstrators.

DECIMAL COUNTERS:

Modulo 10 minimum; inverted M-10-Min; 1-2-4-8; 1-2-4-5; excess 3; 1-2-2'-4; 1-1'-2-5 bi-quinary ring; quibinary ring; half-way addition modulo 10.

DIGITAL TEST INSTRUMENTS, ETC:

Bounceless pushbuttons; 60-Hz power line clock; visual rate clocks; audio high-frequency clock; state indicators; 0.1-second time base; synchronized 0.1-second time base; power line zero-crossing detector; synchronizers; buffer interface; contact conditioner; heads/tails machine; electronic die; pseudo and random number generators; gated oscillator; counter prescaler; reset pulse generator; signal injector; audio oscillator; electronic siren, doorbell, or panic alarm.

Terminal posts insert through foil side of board, soldered to foil, and expoxied to component side.

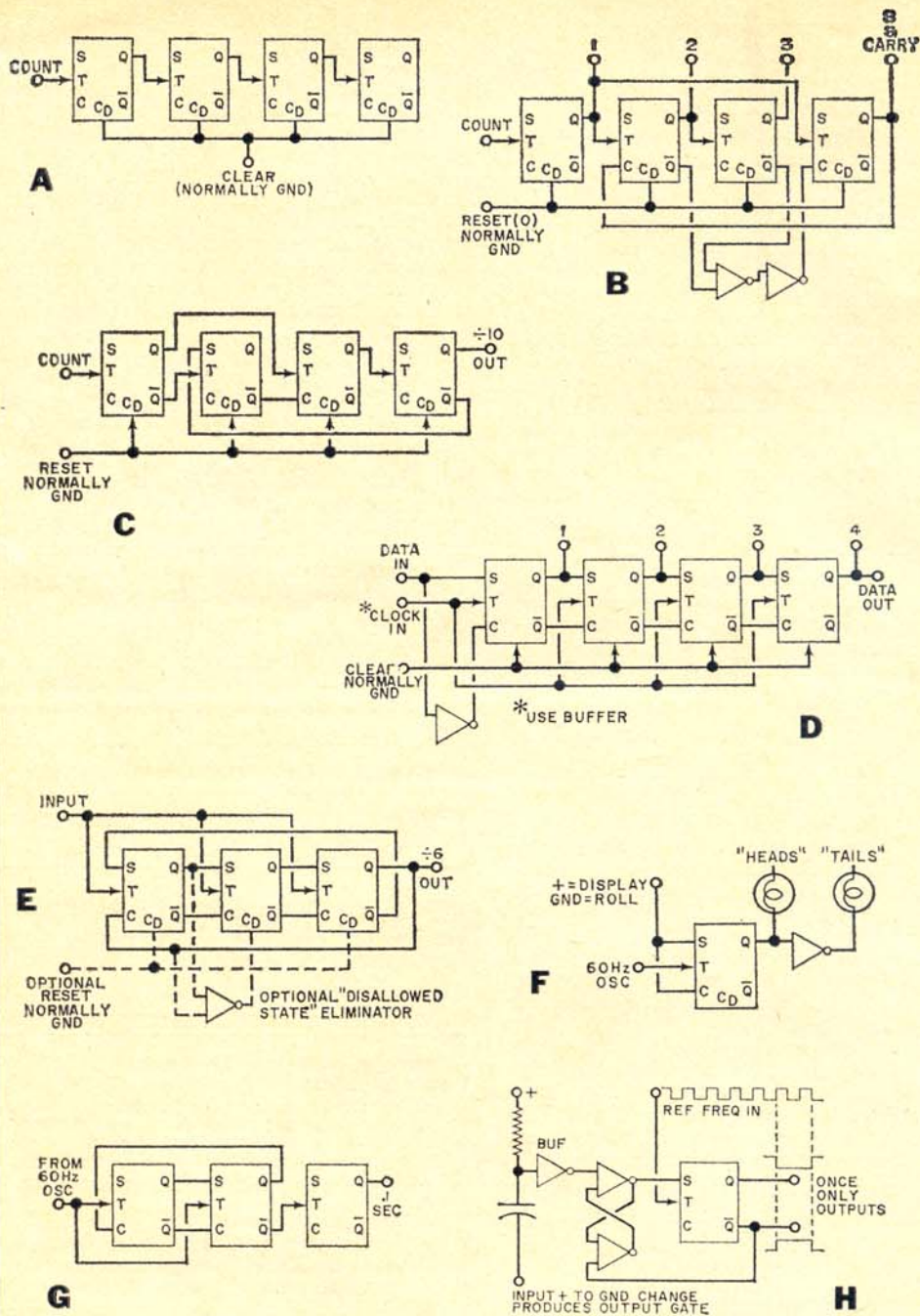

Fig. 9. Some popular digital logic demonstration circuits you can set up are: (A) divide-by-16 binary ripple counter; (B) "1-2-4-8" BCD divide-by-ten counter; (C) "modulo-10 minimum" divide-by-ten scaler; (D) four-stage shift register; (E) divide by six walking ring counter; (F) heads-or-tails "honest odds" coin flipper; (G) 0.1-sec time base (square-wave generator); and (H) "one-and-only-one" synchronizer.

How to Use. The manual prescribed in the Parts List gives many of the experiments you can perform with the Micro-lab. Many of the drawings are in logic block form and ready for instant breadboarding. Generally, you set up an experiment using a logic diagram and the zip leads and then put the circuit through all its possible states in one of several ways.

For instance, you can use the positive and ground reference posts and, by changing zip leads, cycle the circuit. Or you can use the actuators, either as slide switches or by rocking them with two fingers, as pushbuttons.

For automatic experimenting, you can drive the circuit from one of the "clocks" shown in Fig. 7. Figure 7A shows how to use the two RC networks to build a variable low-frequency oscillator that can cycle an experiment at an easy-to-watch, adjustable rate. Figure 7B shows how to build a 60-Hz power-line driven oscillator, which is useful for time bases, heads-tails and random-number circuits, and other cases where you want to cycle the logic faster. Finally, Fig. 7C shows how to create a high-frequency oscillator by cross-coupling the two buffers. This high-speed cycling circuit is most useful when you have an oscilloscope to observe the resulting waveforms or are cycling or testing an external digital instrument.

Several small numbers appear next to terminals on the front panel. These tell you either how much drive is available if the terminal is an output or how much drive is needed if the terminal is an input. For instance, the two-input gate has 13 units of drive available at its output and needs 3 units of drive at either of its inputs. With this gate, you can drive, say, two T inputs (5 units each) and an S input (3 units); but three T inputs (totalling 15) would be too much. Any time you run out of drive capability, run the output through a buffer. Either buffer output is powerful enough (77 units) to drive every input on the board simultaneously. Each of the three switches can put out 13 units of drive power. Use a buffer if you simultaneously (synchronously) drive all four T inputs.

Figure 8 shows some of the more popular digital demonstration circuits. Figure 8A is a binary ripple counter that counts to 16 and then repeats; B is a 1-2-4-8 decimal or divide-by-10 counter;

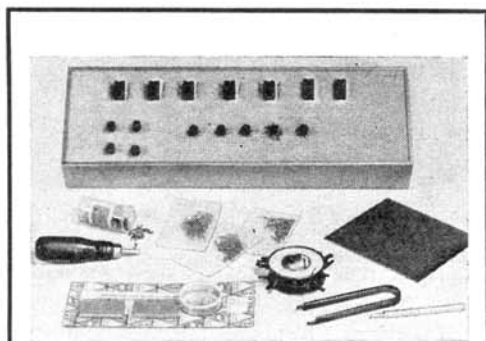

A DIGITAL LOGIC BREADBOARD

Sometimes, the digital logic experimenter would like to put together a circuit consisting of a mixture of 14- or 16-pin in-line IC's, round IC's, some transistors, etc. Obviously, he wants to avoid the constant soldering and unsoldering of IC or transistor leads, since this usually results in component damage.

To help this experimenter, the Vector Electronic Corp. (12460 Gladstone Ave., Sylmar, CA 91342) has a number of logic experimentation kits available. For example, the Model 29X (\$59.75) consists of a 4½" x 14" perforated board supported on all sides by a 2" aluminum extrusion. The sockets provided include ten for 14-pin in-line IC's, two for 16-pin in-line IC's, four for TO-5 transistors (four-lead type), four for 8-lead and two for 10-lead round IC's, and ten 12-hole mounting pads to adapt round IC's to a square hole.

Although primary connections are made through vinyl covered clip leads (50 provided), the kit also includes a mixture of other types of wire connectors used to make up your own test leads. In addition, there are an IC extractor tool, 200 small clip terminals for external component mounting, all required hardware, a couple of small perforated boards, and extra copper wire including 20 feet of the solder-through type. The board can be made without a single solder joint. Once a circuit has been confirmed, the board can be "cleaned off" to await the next project.

C is a modulo-ten minimum-hardware decimal counter; D is a four-stage shift register; E is a walking-ring divide-by-six counter useful in digital clocks and as an electronic die; F is an honest-odds, heads-or-tails coin flipper; G is a 0.1-second time base and square-wave oscillator; H is a one-and-only-one synchronizer that can be used with the time base to get one precise 0.1-second gate under random command every time you flip the switch; I is a divide-by-3 counter; J is a divide-by-five counter; and K is a 15-state pseudo random-sequence generator.