

Taken from the SWTBUG 6800 ROM Monitor Version 1.0 Users Guide

When using SWTBUG® with an MP-A processor card, one board change is necessary since SWTBUG® is a full 1 K ROM and MIKBUG® was a 1/2K device, If this ROM is replacing MIKBUG®, remove MIKBUG® from its socket. On the back side of the MP-A board you will notice that pin 15 of IC-2 (ROM) is grounded. The land coming from pin 15 should be broken and a wire added as shown below.

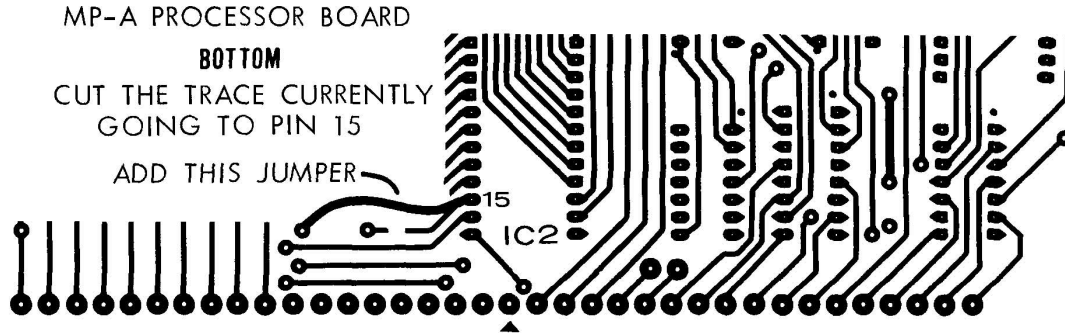

SWTBUG® should now be installed in the socket for IC-2. Be sure to orient the ROM correctly when re-installing. The semicircle notch or dot should match with the MP-A board's component layout drawing.