

DIGITAL / ANALOG TRAINER

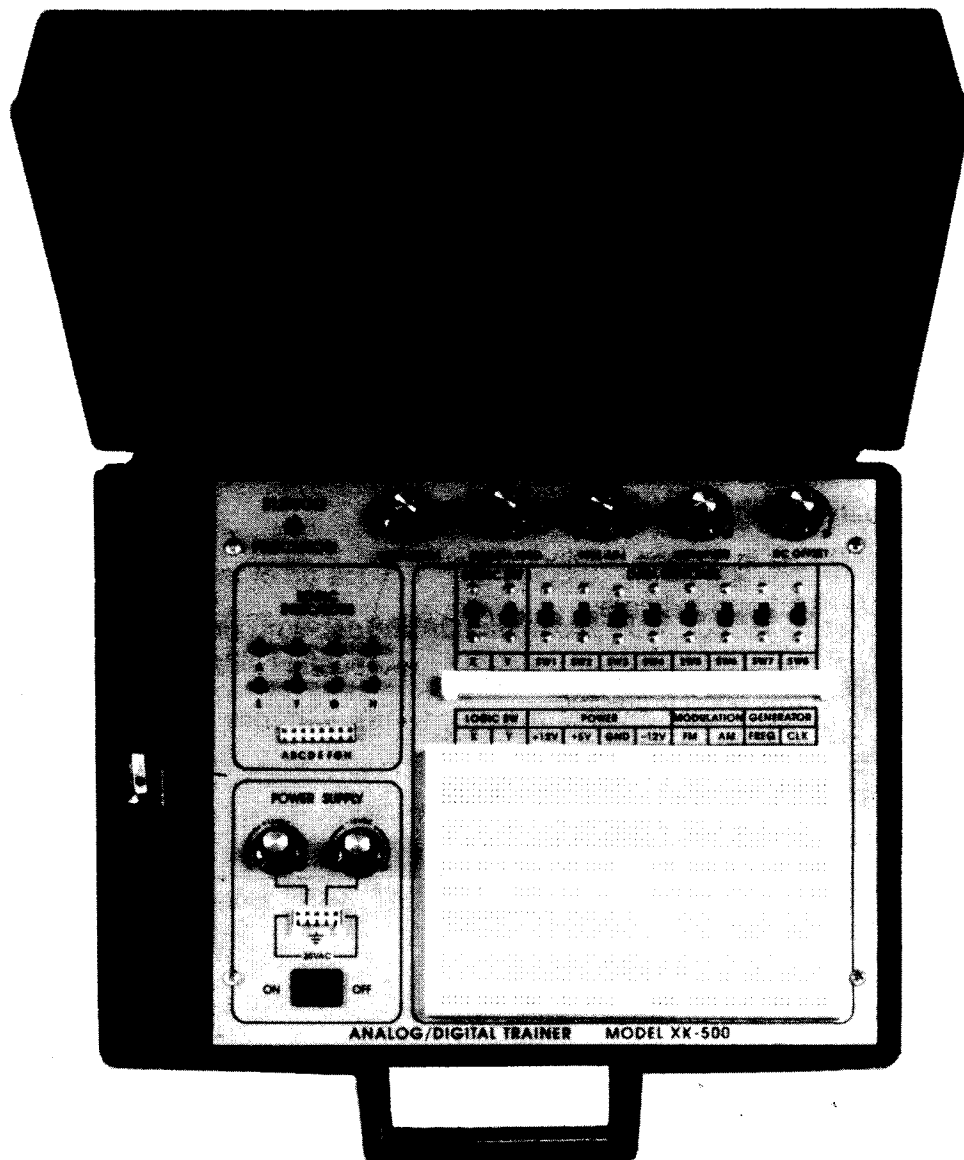

XK-500 Instruction Manual

ELENCO ELECTRONICS, INC.

Specification Model XK-500 Digital Analog Trainer

Power Supplies:

+1.25V to 20V DC @ .5 amp (1.25V to 15V @ 1 amp)
-1.25 to -20V DC @ .5 amp (-1.25V to -15V @ 1 amp)
+12V \pm 5% @ 1 amp.
-12V \pm 5% @ 1 amp.
+5V \pm 5% @ 1 amp.
30V AC center tapped at 15V AC @ 1 amp.
Load regulator all DC supplies less than .2V no load to .5A
Line regulator all DC supplies less than .2V 105 to 135V
Hum and ripple all DC supplies less than .01V RMS
Short protection all DC supplies-Internal IC thermal cutoff
Fuse--3A 250V

Function Generator Analog Section :

Waveforms sine, square, triangle, complimentary square
Frequency - 1 hz to 100 KHz in 5 steps continuously variable
Fine frequency adjust -- 10:1 approximate
Amplitude variable 0-15 VPP.
Output impedance 500 ohms: short protected
DC offset change \pm 10V from zero crossing
AM modulation approx. 25% modulation per volt input
FM modulation approx. 5% freq. change per volt input

Digital Section:

Data switches, eight DPDT, Hi 5V, low 0V
Logic switches, two no bounce with complimentary output
"On" voltage level 2.8V min., "Off" voltage level 1V max.
Input impedance 100K ohm.
Eight LED readouts, 100K ohm input impedance
Clock frequency, 1 Hz to 100 KHz in 5 steps continuously variable
Clock amplitude, 5Vpp squarewave
Clock rise time, better than 100 nsec.

Breadblocks Section:

Two breadblocks containing 840 tie points each (total 1680 pins)
16 independent power bus lines for common connections

USERS DESCRIPTION OF FRONT PANEL CONTROL

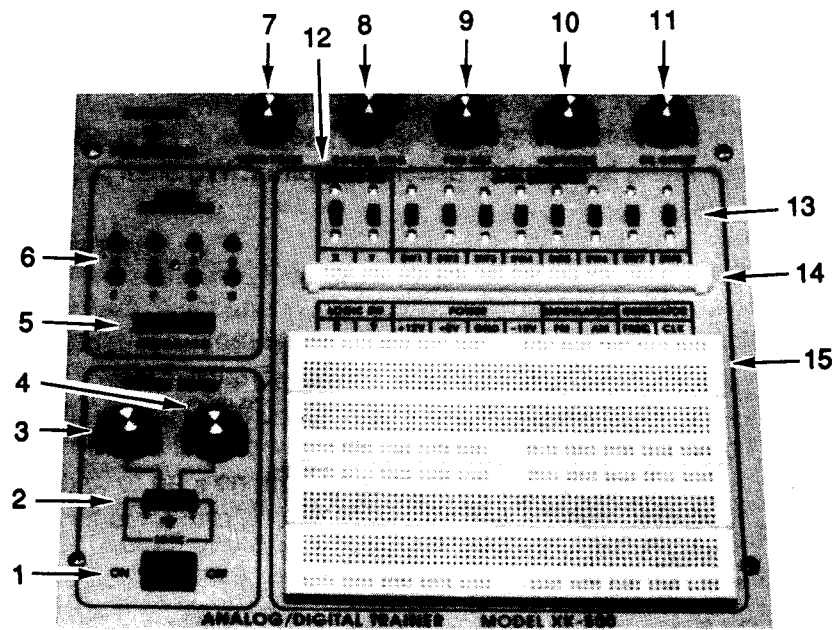

Figure 1

- 1). On-Off switch. Allows power to be applied to all outputs. Switch will light when on.
- 2). Power output terminals. This provides 30VAC center tapped at 15VAC - also provides output terminal for positive and negative variable voltages.
- 3). Variable positive voltage control - Varies positive voltage from 1.25 to 20V at indicated output connector pin.
- 4). Variable negative voltage control - Varies negative voltage from -1.25 to -20V at indicated output connector pin.
- 5). Input points for logic indicators LEDs. "A" input corresponds with A lamp etc.
- 6). Logic indicators LEDs, total eight.
- 7). Waveform selection control, sine, square or triangle generator waveforms.
- 8). Selects five ranges of frequencies from 10 to 100,000 hertz.
- 9). Fine frequency control, allows easy selection of desired function generator frequency.
- 10). Amplitude control - Controls the function generation output amplitude, 0-18Vpp.
- 11). DC offset control. Controls the DC level of the generator output. DC may be varied ± 10 volts from zero level.
- 12). Two logic switches. These are no bounce logic switches. Give one signal state change per movement of switch.
- 13). Eight data switches - Lets output of 5V or 0V depending on position.
- 14). Output terminal for all functions as stated, 5 pins per block.
- 15). Two breadboards containing a total of 1680 tie points including 16 independent bus lines.

INTRODUCTION

Congratulations on your purchase of the Elenco model XK-500 digital/analog trainer. This trainer is designed to simplify designing of digital and analog circuits. It contains most of the necessary test equipment needed to build and test these circuits.

Your XK-500 has four basic trainers in a single package. They are, 5 independent power supplies, an analog trainer, a digital trainer and a breadblock assembly trainer. We shall proceed in describing each trainer in the following sections.

POWER SUPPLY

Model XK-500 has five built-in power supplies which will satisfy most design needs. This includes two variable power supplies giving up to +20 volts and -20 volts at .5 amp. Below 15V the current available is over 1 amp. Three fixed power supplies gives you +12VDC, -12VDC or +5VDC at 1 amp each. These fixed voltage are the most commonly used voltages for design work. All supplies are regulated to within 150MV. This means that you can increase the current draw from no load to .5 amp and the voltage will change less than 150 millivolts. All supplies are also short circuit protected by using integrated circuit regulator devices.

ANALOG TRAINER SECTION FUNCTION GENERATOR

The analog trainer contain a complete function generator capable of producing sine,square, and triangle waveform. The frequency of this generator is continuously variable from one hertz to over 100,000 hertz in five steps. A fine tuning control makes selection of any frequency easy. The output voltage amplitude is variable between 0 to 15VPP. The output impedance is approximately 500 ohms.

The XK-500 generator has capabilities for AM and FM modulation. By applying a external signal to the input of the AM connector the generator output will be amplitude modulated with the external signal. The percentage of modulation depends on the amplitude of the external signal.

By placing a external signal to the FM input connector the generator output will be frequency modulated. This means the generator signal with change frequency with changes in amplitude of the external signal.

DIGITAL TRAINER SECTION

The digital trainer has the necessary functions to do your digital designs. They consist of a clock generator, two no bounce logic switches, 8 LED indicator lamps and 8 data switches. These functions will make it easy to do your digital experiments.

TESTING THE XK-500 DIGITAL ANALOG TRAINER

The following paragraphs give detailed instructions on testing the digital / analog trainer.

Note that in the XK-500 trainer there are five major functions, (1) Power Supply (2) Logic Indicators (3) Function Generator (4) Logic Switches and (5) Data Switches. We shall proceed in testing out each section. If any test fails refer to the schematic diagram and check the wiring and soldering of the section involved.

POWER SUPPLY TESTING

Plug the trainer into 120VAC outlet and switch to the "on" position, the power switch should light. Obtain a digital voltmeter and measure the voltage outputs at the Power blocks. The +12V should measure between 11.2 and 12.8 volts. The 5V supply should read between 4.50 and 5.50 volts. The -12V supply should read between -11.2 and -12.8 volts.

Next short the output of each supply. They should turn off and recover when the short is removed. If you have a 25 ohm 10 watt resistor, place it across the output terminal (2 watt resistor will work but use it only a few seconds). The output of the 12V supply should not change more than .15 volts. Do the same for the -12V output, the output should not change more than .15 volts. Do the same on the 5V supply using a 10 ohm 5 watt resistor. Again the output should not change more than .15 volts. In making this test the voltmeter leads should be clipped to the terminal directly and not to the load leads. This is to prevent errors in voltage drop due to contact resistance of the load.

Check the variable voltage supplies in the same manner. Set the output voltage between 10-15 volts. Place the 25 ohm 10 watt resistor across the output terminal. The voltage should stay within .15 volts of the no load voltage.

TESTING THE FUNCTION GENERATOR

To test the function generator you will need an oscilloscope. Connect the scope to the power plug marked FREQ. and the ground clip to the plug marked GND. Adjust the wave form switch to sine, the coarse frequency switch to 1000 and the amplitude control to maximum. Your scope should show a sine wave with an output of about 15VPP. If the sinewave is clip on top or bottom, adjust the DC offset control for the most linear reading. Turn the FINE ADJ control and the frequency should vary between 100 and 1000 hertz. Move the wave form switch to the other positions. You should see a triangle and square wave. Check out the other positions of the coarse frequency switch, you should be able to obtain a total frequency range of under 1 hertz to over 100,000 hertz.

Now check the CLK output plug. You should see a square wave of about 5VPP. If your scope is a dual trace, connect one input to the CLK and the other to FREQ plug. Set the wave form switch to squarewave. You will note the two frequencies are 180° out of phase. If no scope is available, connect a wire to the CLK plug and input to "A" of the logic indicators. Connect another wire to the FREQ plug and input "B". Set the coarse frequency switch to 10 hertz and the fine freq control to minimum position. The two LEDs should blink alternately.

To test the AM modulation function, you will need another audio generator. Set this generator to around 100 hertz

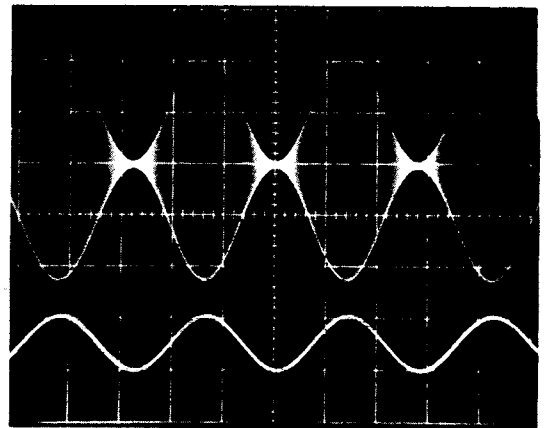

Figure 2

and plug it into the AM input plug and GND. Set the function generator frequency to 100,000 hertz sinewave position. Lock your scope to the 100 hertz and note that the 100 hertz is superimposed in the higher frequency as shown in figure 2. Adjust the 100 hertz amplitude to get about 50% modulation.

Apply the 100 hertz signal to the FM input plug. Here you will see the frequency wiggling at the 100 hertz rate. Try to adjust the scope so it triggers at the 100 hertz rate. It is best to feed the 100 hertz to the external trigger input of the scope and the scope will lock in better.

TESTING THE LOGIC INDICATOR FUNCTION

There are eight logic indicators which you will be checking out. Place a wire to the 5V power supply and touch the "A" logic indicator test pin. The "A" LED should light up. Remove the wire and the LED should go out. Do the same for the B, C, D, E, F, G and H test pins.

TESTING THE LOGIC SWITCHES

There are two logic switches and four conditions to be checked out. Connect a wire from the "X" test pin to the "A" logic indicator test pin. Connect another wire to the "X̄" test pin to the "B" test pin.

Apply power and note that the "A" LED indicator should be lite when the logic switch is in the "X" position and the "B" LED is not lite. Moving the logic switch to the "X̄" should reverse the indicator LEDs, that is the "B" LED should light and the "A" LED not light. Check the Y logic switch in the same manner.

TESTING THE DATA SWITCHES

There are eight data switches to be checked. The output of the switches are at 5V or ground depending on position. Connect a wire to SW1 test pin and the "A" test pin, the "A" LED should light when the switch is placed toward the top of the case. Repeat the same test on SW2, SW3, SW4, SW5, SW6, SW7 and SW8.

This completes the testing of the trainer.

CIRCUIT DESCRIPTION

INTRODUCTION

The model XK-500 power supply features two variable output voltages and three fixed 12V, -12V and 5V, variable output voltages are 1.25V to 20V and -1.25 to -20V at up to 1 ampere maximum current. All supplies are regulated to better than .2V when going from no load to full load. Varing the input AC voltage from 105 to 135V will have practically no effect on the output voltages. This is because of the specially designed IC circuits used in the XK-500 circuits. Severe overloading or even shorting the output circuits will not damage the supplies. Special turn-off circuits in the IC sense the overload and turn off the output.

THE POSITIVE 1.25 TO 20V POWER SUPPLY

Figure 3 shows a simplified circuit diagram of the positive supply. It consists of a power transformer, a DC rectifier stage and the regulator stage.

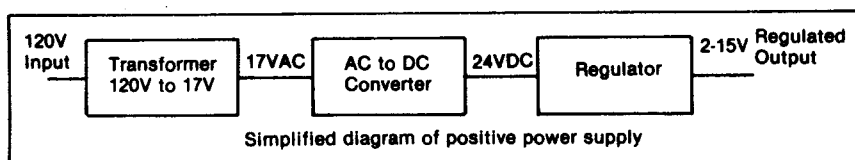

Figure 3

TRANSFORMER

The transformer T1 serves two purposes. First, it reduces the 120VAC input to 17VAC and 8VAC to allow the proper voltage to enter the rectifier stages. Second, it isolates the power supply output from the 120VAC line. This prevents the user from dangerous voltage shock should he or she be standing in a grounded area.

AC TO DC CONVERTER

The AC to DC converter consists of diodes D1, D3 and capacitor C1. Transformer T1 has two secondary windings which are 180 degrees out of phase. The AC output at each winding is shown in figure 4A and 4B.

Diodes are semiconductor devices that allow current to flow in one direction. The arrow in figure 5 points to the direction current will flow. Only when the transformer voltage is positive will current flow through the diodes. Figure 5 shows the simplest possible rectifier circuit. This circuit is known as a half-wave rectifier. Here the diode conducts only half the time when the AC wave is positive as shown in 4C. Use of this circuit is simple but inefficient. The big gap between cycles require much more filtering to obtain a smooth DC voltage.

By the addition of a second diode and transformer winding we can fill in the gap between cycles as shown in figure 6. This circuit is called full-wave rectification.

Each diode conducts when the voltage is positive. By adding the two outputs, the voltage presented to capacitor C1 is more complete, thus easier to filter, as shown in figure 4E. When used in 60 cycles AC input power, the output of a full wave rectifier will be 120 cycles.

Capacitor C1 is used to store the current charges, thus smoothing the DC voltage. The larger the capacitor, the more current is stored. In this design 1000ufd capacitors are used, which allows about 5 volts AC ripple when one amp is drawn.

In practice the current through the diodes is not as shown in figure 4C. Because capacitor C1 has a charge after the first cycle, the diode will not conduct until the positive AC voltage exceeds the positive charge in the capacitor. Figure 7 shows a better picture of what the current flow looks like assuming no loss in the diode.

It takes a few cycles for the voltage to build up on the capacitor. This depends on the resistance of the winding and diode. After the initial start-up, there will be a charge and discharge on the capacitor depending on the current drawn by the output load. Remember current only flows through the diode when the anode is more positive than the cathode. Thus current will flow in short bursts as shown in figure 7.

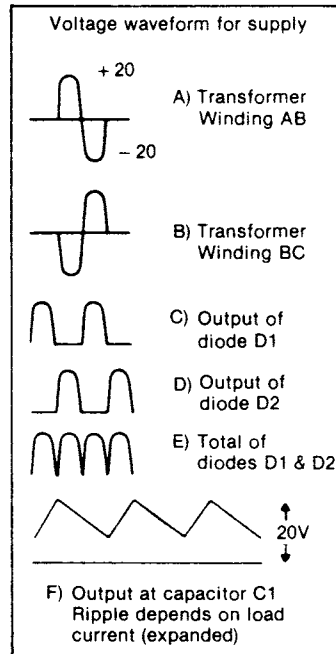

Figure 4

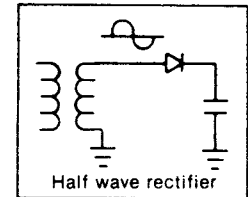

Figure 5

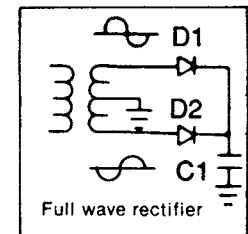

Figure 6

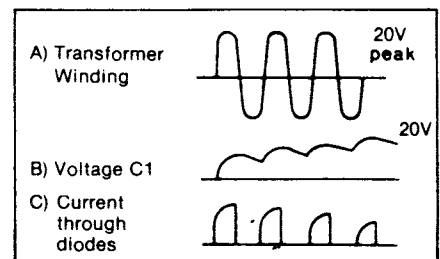

Figure 7

The DC load current may be one ampere but the peak diode current may be three times that. Therefore, the diode rating must be sufficient to handle the peak current. The IN4001 has peak current rating of 10 amps.

REGULATOR CIRCUIT

The regulator circuit in the model XK-500 power supply consists of a LM-317 integrated circuit. This IC is specially designed to perform the regulation function. Figure 8 shows a simplified circuit of how the LM-317 IC works.

Transistors Q1 and Q2 form a circuit known as a differential amplifier. Transistor Q1 base is connected to a stable 1.5V reference voltage. The base of Q2 is connected to the regulator output circuit through a voltage divider network. The collector of transistor Q2 is connected to a current source. This basically is a PNP transistor biased to draw about 1mA current. Transistor Q2 sees the current source as a very high resistor of about 1 meg ohms. Thus the gain of transistor Q2 is extremely high.

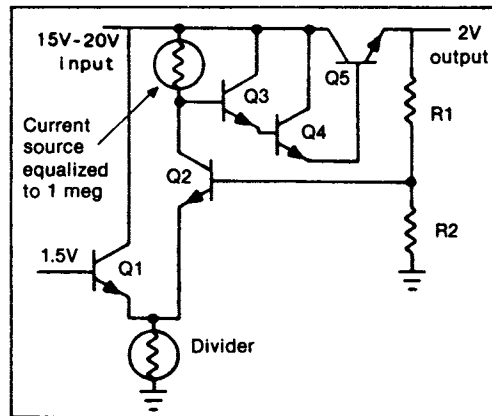

Figure 8

Transistor Q5 is called the pass transistor. It controls the current reaching the output. Transistor Q3 and Q4 are emitter followers. Their function is to raise the impedance of the pass transistor. Note that transistor Q2, Q3, Q4, Q5 and resistor R1 form a close loop. Also note that the feedback to the base of Q2 is negative, that is when the base of Q2 goes positive, the output at emitter Q5 goes negative. Now if the 2V output voltage goes down because of current drain at the output, the base of Q2 will drop forcing the collector voltage of Q2 to go higher. This will bring the output voltage back to 2V. This is the basis of all negative feedback regulators.

Another feature of the LM-317 regulator is to protect the IC against overload and output shorts. If the IC is overloaded, the junction of an overload transistor will overheat. A transistor will sense this overheating and shut down transistor Q5.

The LM-317 IC is basically a 1.25V regulator. To be able to vary the output 1.25 to 20V we stack the IC on a DC voltage as shown in figure 8A. When VR1 equals 0 the output voltage is 1.25V as determined by the LM-317 IC. Note that the voltage across R1 is always 1.25 volts. When R1 equals VR1, the voltage across VR1 will equal the 1.25 volts across R1, therefore the output voltage will be 2.5 volts. When VR1 is 5 times R1, the output voltage is 6.25 volts. As you can see varying resistor VR1 will vary the voltage from 1.25 to 20V.

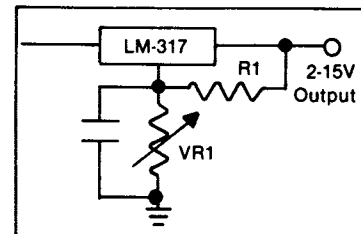

Figure 8A

THE NEGATIVE VOLTAGE REGULATOR

The theory of the negative voltage regulator is the same as the previously discussed positive regulator. The basic differences is that the diode D1 and D3 are reversed producing a negative voltage across capacitor, C1. The LM-317 IC is designed to operate from a negative supply.

THE DATA SWITCHES

There are eight data switches, labeled SW1 to SW8. The circuit is very simple. To perform the desired functions there is a double throw double pole switch. One end is connected to the 5V, the other to ground and the center lug is connected to the output.

THE LOGIC SWITCHES

The logic switches perform the same function as the data switch, that is produces high or low states. But there is one big difference, then switching the data switches many pulses may be produced due to bouncing of the contacts.

In the logic switches only one pulse is produced no matter how many times the contacts bounce. This is extremely important if you are producing pulses for counting circuits. Figure 9 shows the wiring of the logic switch. The two NAND gates are connected so that when X input is grounded the output X goes high. Opening and closing the ground at X will not change the output. Only when \bar{X} is grounded will the output change to low. Thus only one output change is produced with one movement of the X switch. There are two outputs from each logic switch, X and \bar{X} or Y and \bar{Y} .

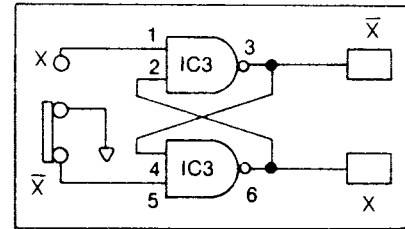

Figure 9

THE FUNCTION GENERATOR

The function generator frequencies are produced by a XR 2206 integrated circuit. This IC is capable of producing high quality sine, square and triangle waveform of high stability and accuracy. The output waveform can be both amplitude and frequency modulated by an external voltage. Figure 10 shows the block diagram of the XR-2206 IC.

The XR-2206 is comprised of four functional blocks; a voltage-controlled oscillator (VCO), an analog multiplier and sine-shaper; a unity gain buffer amplifier; and a set of current switches.

The VCO actually produces an output frequency proportional to an input current. Across pins 5 and 6 a timing capacitor is switched in to give 5 different ranges of frequencies via COARSE FREQ. switch. On pin 7 the FINE FREQ. ADJ. variable resistor controls the actual frequency output. These two components form the RC time constants for the oscillator frequency.

The VCO produces a squarewave signal. This squarewave is sent to a shaper and converted into a sine wave.

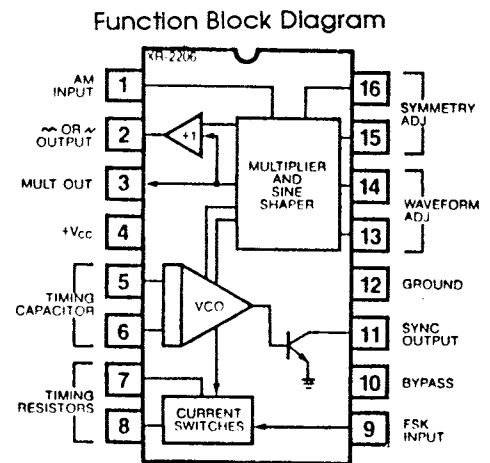

Figure 10

THE LOGIC INDICATORS

There are eight logic indicators. Figure 11 shows the circuit. It consists of a 74HC04 IC. When the input is over 2.8V the output of the IC will be low, drawing current through the LED indicator. The 120 ohm resistor limits the current in the LED to about 30mA.

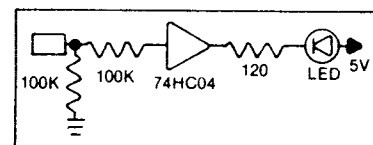
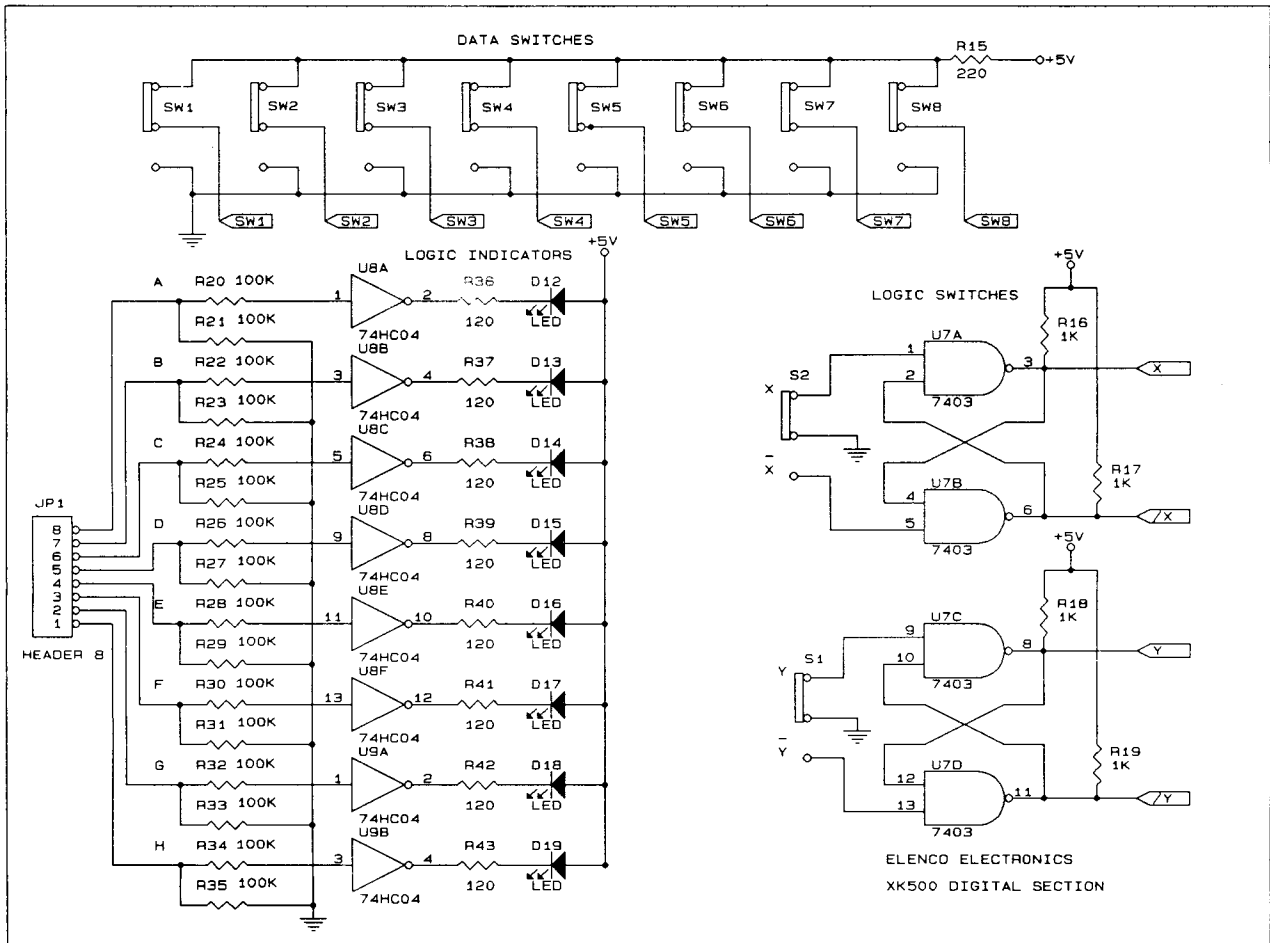
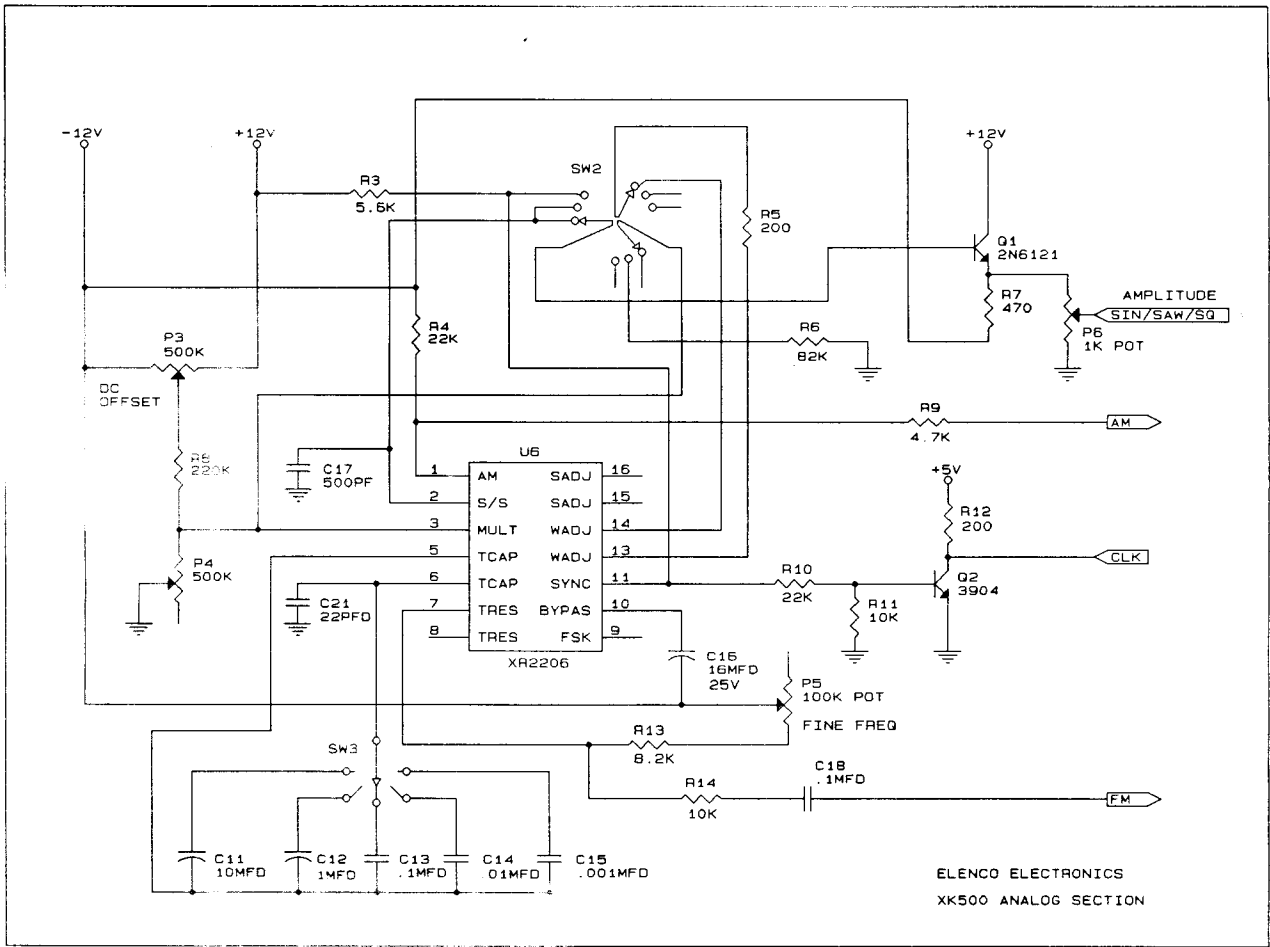
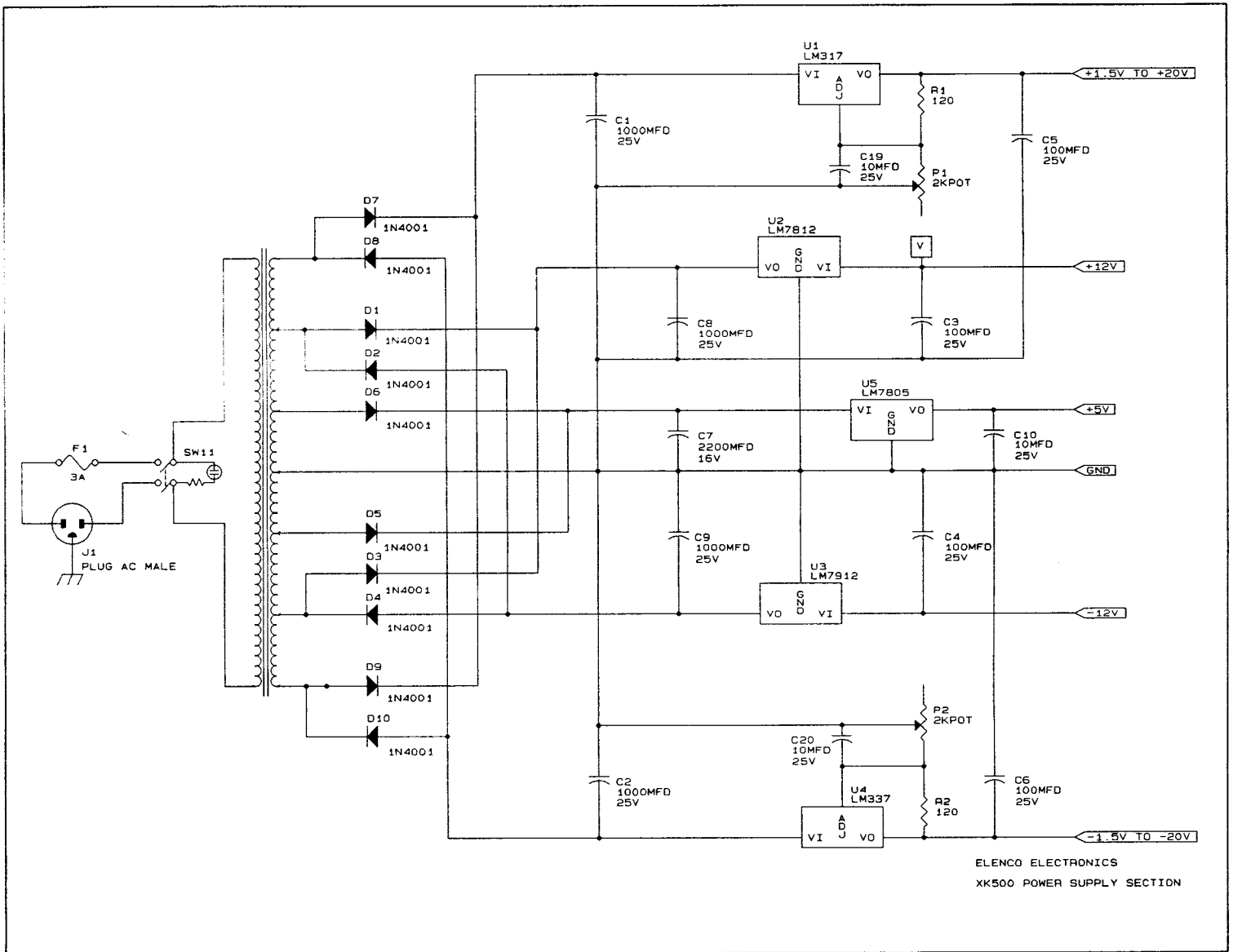

Figure 11

PARTS LIST

Qty	Description	Part No.	Qty	Description	Part No.
Resistors			Miscellaneous		
10	120 OHM 1/4W Brn-Red-Brn-Gold	131200	1	Transformer	44K500
2	200 OHM 1/4W Red-Blk-Brn-Gold	132000	1	PC-Board Main	514500
	220 OHM 1/4W Red-Red-Brn-Gold	132200	1	PC-Board Digital	514501
1	470 OHM 2W Yel-Vio-Brn-Gold	134703	1	Fuse 3A	530300
4	1K OHM 1/4W Brn-Blk-Red-Gold	141000	1	Illuminated Switch	541204
1	4.7k OHM 1/4W Yel-Vio-Red-Gold	144700	1	Connector 5 Pin	501051
1	5.6k OHM 1/4W Grn-Blu-Red-Gold	145600	1	Connector 8 Pin	591108
1	8.2k OHM 1/4W Gry-Red-Red-Gold	148200	1	Panel Top	614150
1	10k OHM 1/4W Brn-Blk-Org-Gold	151000	2	Panel Side	614550
2	22k OHM 1/4W Red-Red-Org-Gold	152200	7	Knob	622008
1	82k OHM 1/4W Gry-Red-Org-Gold	158200	1	Case	623025
16	100K OHM 1/4W Brn-Blk-Yel-Gold	161000	1	Strain Relief	624003
1	220k OHM 1/4W Red-Red-Yel-Gold	162200	3	PCB Support	625003
1	1K Potentiometer	192410	20	Screw 2-0.5x8	643148
1	2K Potentiometer	192420	1	Screw 2-56x1/2	641232
1	100K Potentiometer	192610	2	Screw 4-40x1/2	641463
1	500k Potentiometer	192660	5	Screw 6-32x5/16	641641
1	500K Trim Pot	911631	4	Screw 6-32x1/2	641665
Capacitors			2	Screw 8-32X3/8	641840
1	500PF Disc	225080	6	Screw 4x1/4	642430
1	.001uF Mylar	231017	1	Nut 2-56	644201
1	.01uF Disc	241017	2	Nut 4-40	644400
2	1uF Mylar	251017	4	Nut 6-32	644600
1	1uF 35V Electrolytic Radial	261046	5	Nut 6-32 Small	644601
2	10uF 16V Electrolytic Radial	271043	2	Nut 8-32	644800
1	10uF 25V Electrolytic Radial	271045	2	Nut Pot 3/8x32	644960
2	10uF 25V Electrolytic Axial	271055	6	Lockwasher #8	646828
1	100uF 16V Electrolytic Radial	281044	5	Lockwasher 3/8	646900
4	100uF 25V Electrolytic Radial	281045	1	Solder Lug #8	661002
4	1000uF 25V Electrolytic Radial	291045	1	Fuse Holder	663000
1	2200uf 25V Electrolytic Radial	292225	20	Block Mounting Pins	665540
Semiconductors			1	Breadstix 9406	665588
10	1N4001 Diode	314001	1	Label	723500
1	LM-317 IC	330317	4	Insulator Mica	780002
1	LM-337 IC	330337	4	Insulator Washer	780101
1	LM-7805 IC	337805	1	Line Cord	862105
1	LM-7812 IC	337812	1	Shrink Tubing 1/2 DIA	891101
1	LM-7912 IC	337912	2	Breadblox 9840	99840
1	2N3904 Transistor	323904	1	Switch Rotary 2P5POS	542205
1	2N6162 Transistor	326121	1	Switch Rotary 4P3POS	542403
1	XR2206 IC	332206	10	Switch Slide DPDT	541107
1	2N7403 IC	337403	1	Socket IC 16 Pin	664016
2	74HC04 IC	39HC04	3	Socket IC 14 Pin	664014
8	LED Diode (red)	350002	10	Spacer 1/4 #8	624124





WARRANTY POLICY

The XK-500 has been tested and conforms to our rigid requirements on performance and durability. It is guaranteed to be free of defects in workmanship, materials and construction for a period of 3 years. If this product should fail in normal use within the first 3 months from the date of purchase, Elenco will repair or replace the unit at no cost. For the remainder of the warranty period a nominal service charge is required to cover shipping and handling.

Direct all warranty inquiries to:

Elenco Electronics, Inc.
150 W. Carpenter Ave.

Service Department
Wheeling, IL 60090

Elenco Electronics, Inc. • 150 W. Carpenter Ave., Wheeling IL 60090 • (708)541-3800